

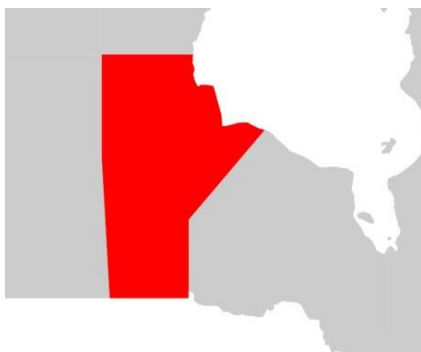

# BOOKLET 10: ACOUSTICS

## TECHNICAL GUIDE FOR NORTHERN HOUSING

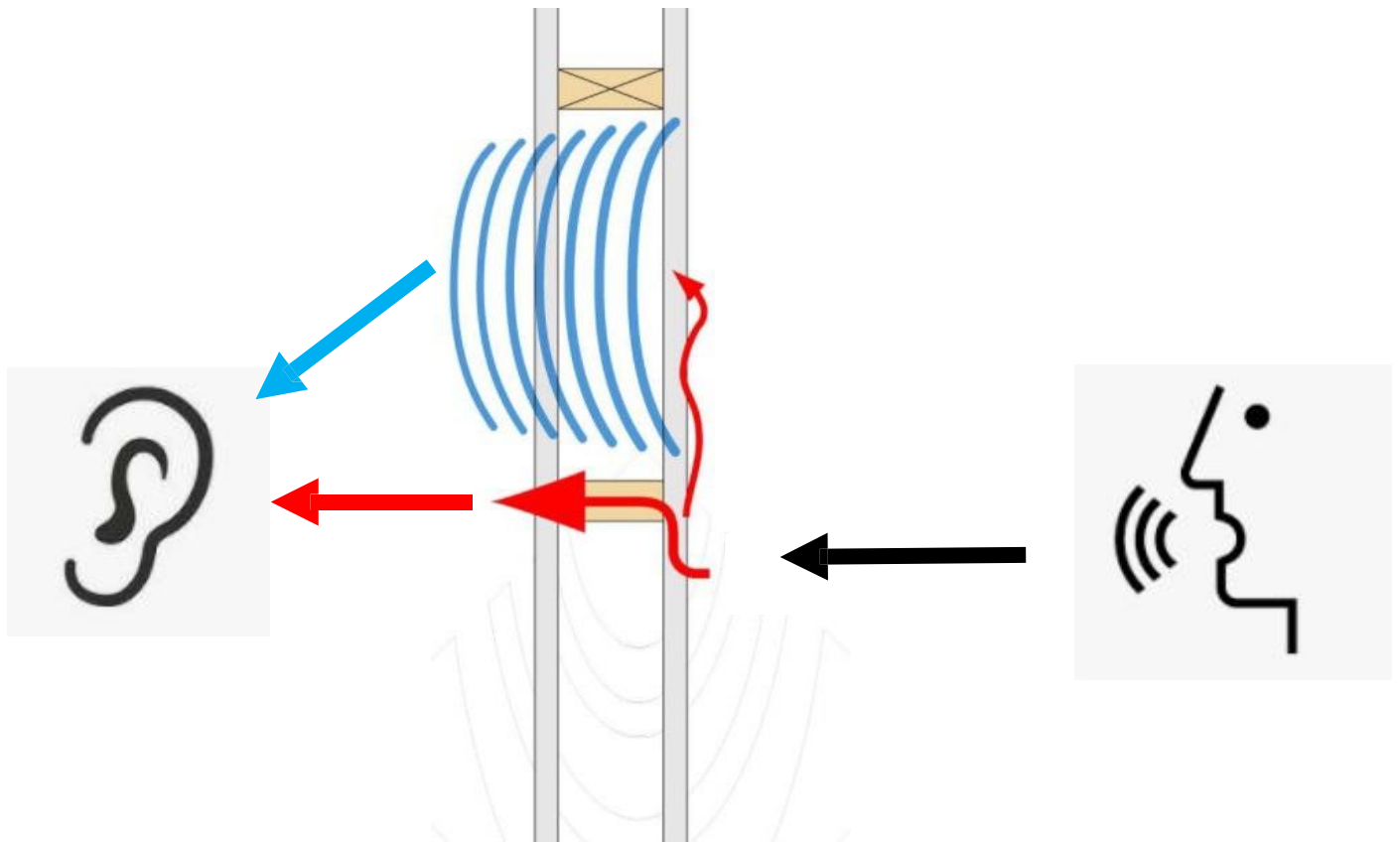

TAILORED FOR REMOTE NORTHERN MANITOBA COMMUNITIES





## DISCLAIMER

The information in this publication is based on the most current research available to FNNBOA and has been reviewed by housing industry experts. Readers are advised to evaluate the information, materials and techniques carefully and to consult appropriate professional resources to determine courses of action suitable for their situations. The figures and text are intended as general practice guides only. Project and site-specific factors of climate, cost, geotechnical conditions and architecture must be taken into consideration. Any photographs in this book are for illustration purposes only and may not necessarily represent currently accepted standards. Electronic reproduction of content or this publication is made available for information only and is not an official version of the document. Individuals who download these documents do so at their own risk. FNNBOA will not be responsible for any damage to your computer or any of the information on it.

This document, or any discrete portion of this document (such as a chapter or section) may be reproduced for redistribution, without obtaining the permission of FNNBOA, provided that no changes whatsoever (including translation) are made to the text; that the entire document or discrete part is reproduced; that this copyright notice is included in its entirety in any and all copies of the document or any discrete part of the document; and that no use is made of any part of the document, or the name or logo of the owner of the copyright to endorse or promote any product or service. For any use of this document other than reproduction or for the general reference purposes as set out above, please contact First Nations National Building Officers Association at [info@fnnboa.ca](mailto:info@fnnboa.ca). For permission, please provide FNNBOA with the following information: Publication's name, year and date of issue.

First Nations National Building Officers Association  
5731 Old Hwy #2, P.O. Box 219  
Shannonville, Ontario K0K 3A0  
[www.fnnboa.ca](http://www.fnnboa.ca)

Tel (613)236-2040  
[info@fnnboa.ca](mailto:info@fnnboa.ca)

1<sup>st</sup> Edition [June 2022]

Provided by FNNBOA under licence from the National Research Council of Canada



## The story of sound transmission in northern houses

Noise from neighbours in connected housing is a primary reason people prefer detached single-family houses over multi-unit residential homes. Wood-frame residential construction can be susceptible to noise transfer through walls, ceilings and floors if not properly planned and constructed to block sound transfer. There are proven approaches for wood-frame construction that can reduce sound transmission through walls, floors and ceilings to the point of being nearly soundproof.

Attempts at soundproofing areas within a house commonly result in disappointment (i.e. little noticeable benefit after money and effort has been spent). In part, this is because sound moves in multiple ways. Sound is intense waves in the air. Airwaves are created by the vibration of a more solid material. A combination of solutions is required to reduce sound transmission: plugging holes where air can move and stopping harder materials from vibrating.

- ◆ Parts of the house where air can flow freely will readily transmit sound, such as through the gap under doors, in ventilation and heating ducts and holes in walls at electrical sockets. Plugging the holes helps reduce sound transmission but it can also complicate the heating and ventilation of a house.
- ◆ Wood framing readily transmits sounds through contact; air vibrations cause the wallboard and wood to vibrate, which causes the air on the other side to vibrate, creating airwaves. To prevent vibrations transmitting through the structure (wall studs and floor/ceiling joists), either full structural separation of one area of the house from the other could be done (expensive), or vibration dampening of the more solid materials is needed (this takes design and installation experience).

Structural separation is what the code requires at party walls/firewalls that separate housing units in a duplex and other multi-unit buildings.

Within a detached single-family house, it is not practical or cost-effective to make some parts of the house “soundproof” from other parts of the house. However, reliable soundproofing between attached housing units can be accomplished in a cost-effective, practical and complementary manner to the fire separation requirements in the building code. Many measures for soundproofing also provide fire separation. In general, construction approaches that reduce fire and smoke spread between units also significantly reduce sound transmission.

**If people are considering living together in a single-family house, but desire acoustic privacy (e.g. a young family with children and grandparents), a duplex separated with a soundproof party wall is a much more suitable living arrangement, from an acoustics perspective.**



## The story of sound transmission in northern houses

Building multi-unit residential housing is generally a more cost-effective approach to housing people than single-family homes, from both a construction-cost and heating perspective. For example, each unit in a duplex shares a wall with the other unit; this wall does not lose heat to the outside and does not require exterior siding. For communities with a shortage of housing, multi-unit residential construction is an option to help provide more housing with limited financial resources.

Multi-unit residential housing does not mean just low-rise apartment buildings to realize a significant benefit. For example, assume it costs \$1 million to build two detached single-family homes, each with 1,000 square feet of interior space, and it costs \$900,000 to build a duplex with two 1,000-square-foot units. The total interior housing space between options is the same. If the community had \$10 million, it could build 20 detached houses, or 11 duplexes, with a total of 22 units. The duplex option would provide two more homes (or an additional 2,000 square feet of housing) for the community than the detached single-family housing approach. Also, the cost of heating each unit would be less.

**Note:** This booklet is focused on multi-unit residential housing that falls within Part 9 of *The National Building Code (NBC)*. This means buildings that are three storeys or less and have a building area of 600 m<sup>2</sup> or less (a 6,455 ft<sup>2</sup> maximum footprint). Larger multi-unit residential buildings fall under Part 3 of the *NBC* and require a licensed architect in the design of the building.

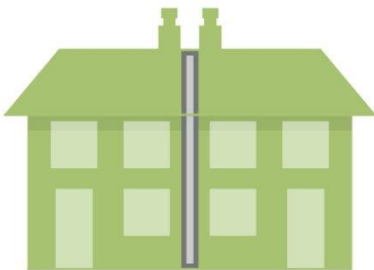

**This booklet focuses on soundproof construction of the separation wall\* between dwelling units, such as the separation wall between the two units of a duplex.**

\* As structural loads are primarily vertical, it is more difficult to achieve structural and therefore sound separation between stacked units where the floors are the separation plane. Structural and sound separation is easier to achieve in side-by-side units, with the wall as the separation plane. This guide recommends avoiding housing configurations where units are stacked, as adequate soundproofing will be difficult to achieve, given the material and construction constraints in remote northern communities.



## READ THIS BOOKLET IF YOU NEED TO:

1. Incorporate sound separation between residential housing units.
2. Understand how sound travels through homes and what construction approaches are effective at reducing sound transmission.

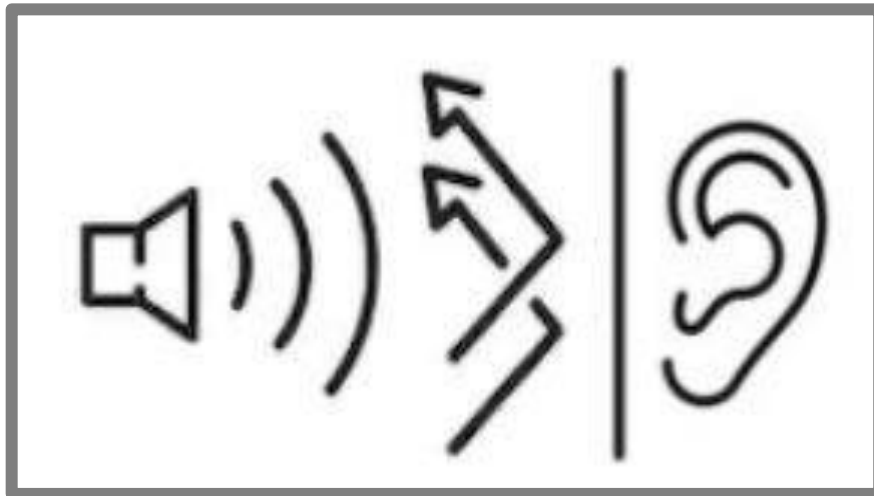

*Healthy—The goal is to advise on housing approaches that are most likely to result in healthy living conditions and community well-being (i.e. avoid conflicts, stress and disturbance caused by disruptive sounds travelling between house residents).*



## HOW SOUND TRAVELS

Before thinking about how to block sounds from travelling between spaces (“sound transmission”), one must understand the different ways sound travels. All types of sound transfer need to be blocked for an effective reduction in noise movement within a house.

- Vibrations in the air
- Holes in walls, ceilings and floors
- Vibrations in the structure

Creating soundproof rooms or spaces within a house can be challenging. Simply adding an extra layer of drywall and/or batt insulation to an interior partition wall will often provide marginal improvement to the sound rating of the wall since the other methods for sound transmission can dominate.

**Flanking paths are often the weak link!** In the sketch below, the green, blue and dashed lines are the flanking paths. The red arrows are the direct path. Flanking sound bypasses the soundproofing in the wall or floor.

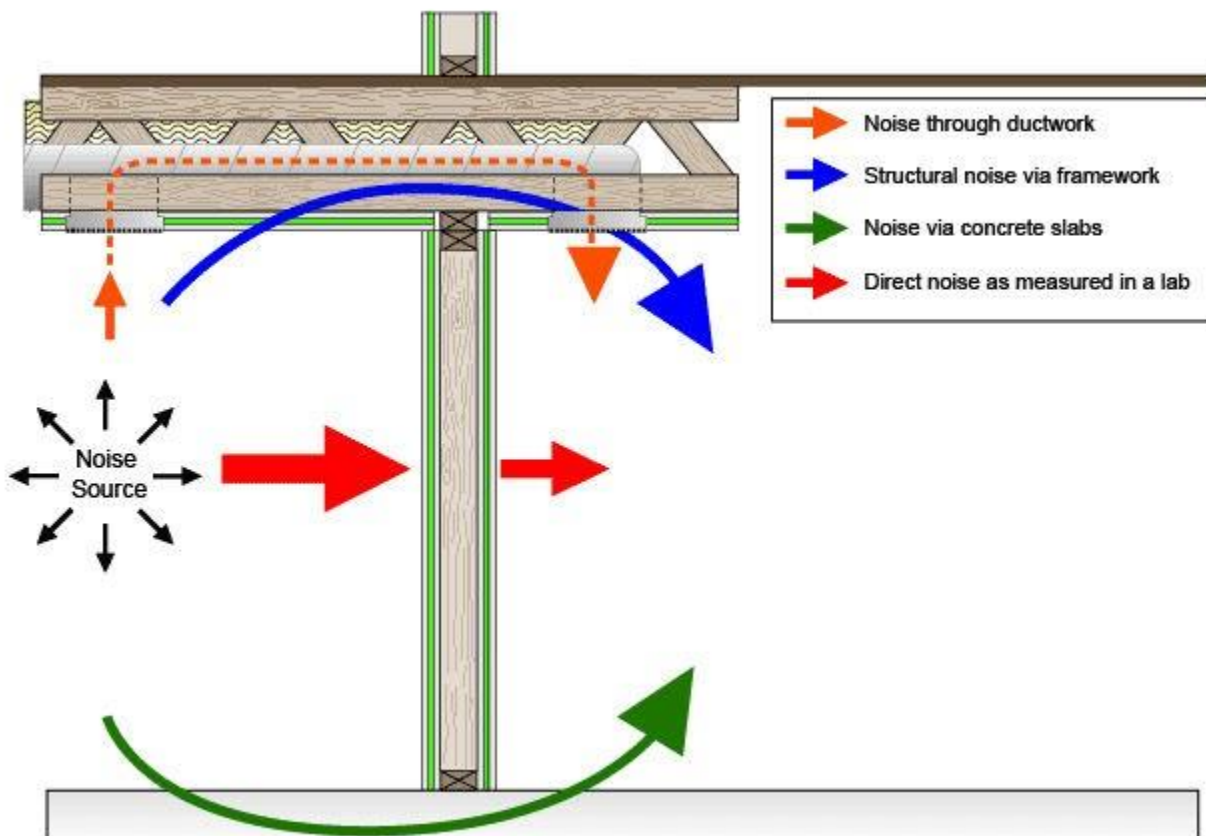



## How do I tell how soundproof a wall is?

The *National Building Code (NBC)* uses two ratings for sound. The first is called the sound transmission class (STC), and the second is called apparent sound transmission class (ASTC). The STC addresses only direct sound movement, whereas the ASTC considers the flanking paths as well. The National Research Council of Canada (NRC) has tested numerous types of wall construction to determine the STC for each one. Therefore, you can get a good idea of how well a wall will resist sound transmission by comparing it to similar wall types that have been tested and have a published STC. In the *NBC*, ASTC, and STC requirements are provided in Division B, Part 5 *Environmental Separation*, Section 5.8, and Part 9 *Housing and Small Buildings*, Section 9.11, with supporting examples in Appendix Note A-9.11.

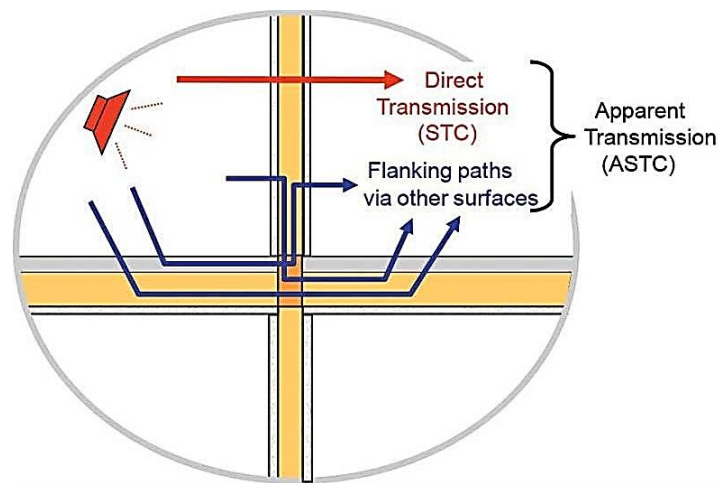

STC testing is limited to certain frequencies of airborne sounds that are within the range of common speech and music. STC is not a good indicator for sound reduction of high-frequency sounds, very low-frequency sounds, or impact sounds. The following is a rough guide on what different STC values mean, in the context of how much of the noted sound can be heard on the other side of an assembly with the noted STC rating:

- STC = 25, normal speech can easily be understood
- STC = 30, loud speech can be understood
- STC = 35, loud speech can be heard but not understood
- STC = 45, loud speech can be faintly heard, but not understood
- STC = 50, loud sounds can be faintly heard
- STC = 60, most sounds would not disturb people in the other unit

A typical interior partition wall made with 2x4 studs and 1/2" drywall and no insulation has an STC of 32. Loud talking can be easily heard through these typical partition walls.

The *NBC* requires separating walls between housing units to have a minimum STC of 50.



## Summary of elements that make a soundproof wall

- 1) **Use sealant:** to stop sound transfer through air gaps and holes.
- 2) **Build a double stud wall:** to separate the structure between units.
- 3) **Fill the wall cavity with batt insulation:** to absorb air vibrations inside the wall cavity.
- 4) **ADD MASS:** Install double layers of drywall to both sides of the wall to absorb the energy of low-frequency sounds.
- 5) Use “**resilient channels**” when installing drywall, which prevents direct transmission of vibration from the drywall into the framing of the wall. See red arrows below.

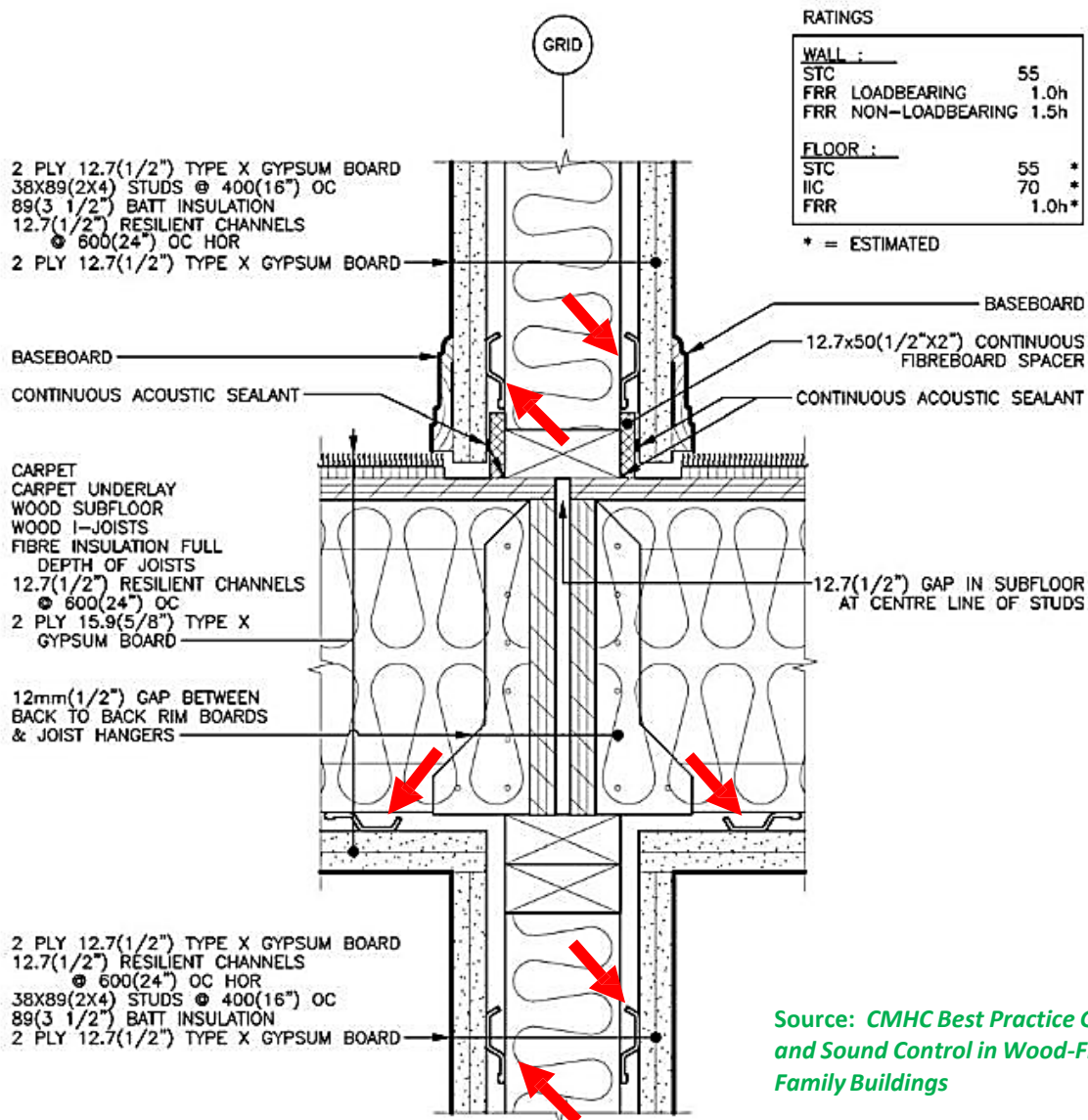

Source: *CMHC Best Practice Guide: Fire and Sound Control in Wood-Frame Multi-Family Buildings*



1) **Use sealant:** to stop sound transfer through **air** gaps and holes.

Sweep away dust/debris before placing wall bottom plate and install sealant.

- Apply sealant at bottom edge of drywall.
- Seal electrical boxes to the drywall and seal holes where wires leave the box.

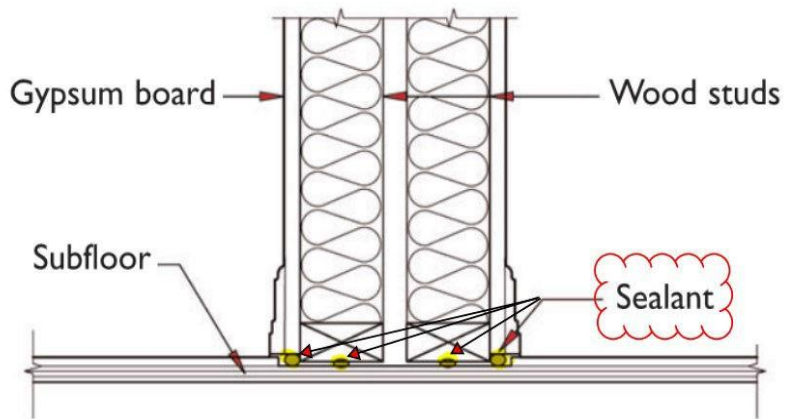



2) **Build a double stud wall:** to separate the structure between units.

- Floor joists end and rest on one side of the double stud wall.
- A gap in the plywood flooring is needed to prevent sound vibrations from travelling across the separation.

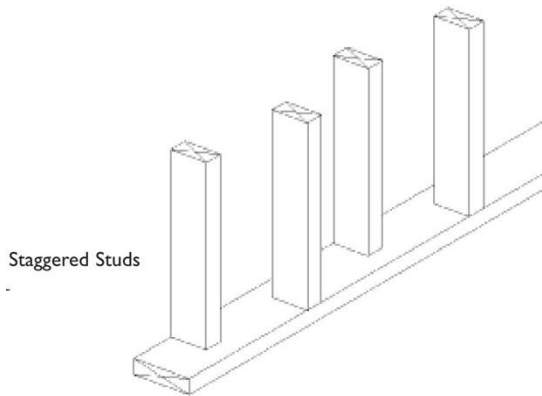
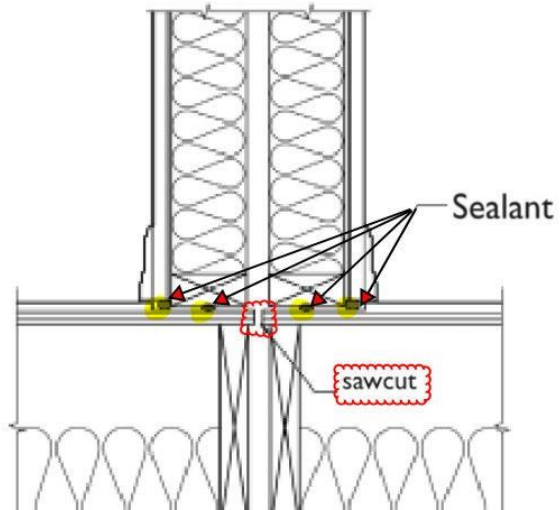
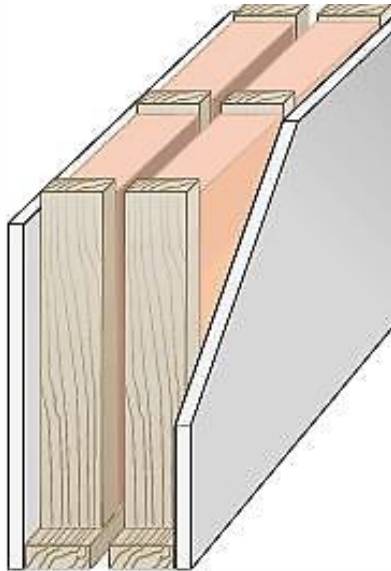

Staggered studs are better than a single row of studs, but still not as good as double studs, because the bottom plate acts as a sound bridge.

Resilient channels are horizontal channels installed to the studs or joists. They reduce the amount of contact between drywall and framing, which reduces vibration transmission. Resilient channels require careful installation of the drywall screws to avoid contact with the framing behind the channels. If care is not taken, much of the sound-reducing benefit of the channels will be lost.





3) **Fill the wall cavity with batt insulation:** to absorb air vibrations inside the wall cavity.

- At least two-thirds of the wall cavity should be filled with batt insulation
- Mineral-fibre batt insulation is recommended over fibreglass batt insulation due to its greater resistance to fire.





4) **ADD MASS:** Install double layers of drywall to both sides of the wall:

- The heavier the wall is, the more sound energy it takes to make it vibrate.
- Use Type X gypsum board for slightly better sound reduction than regular gypsum board (Type X has a fire-resistance benefit as well).

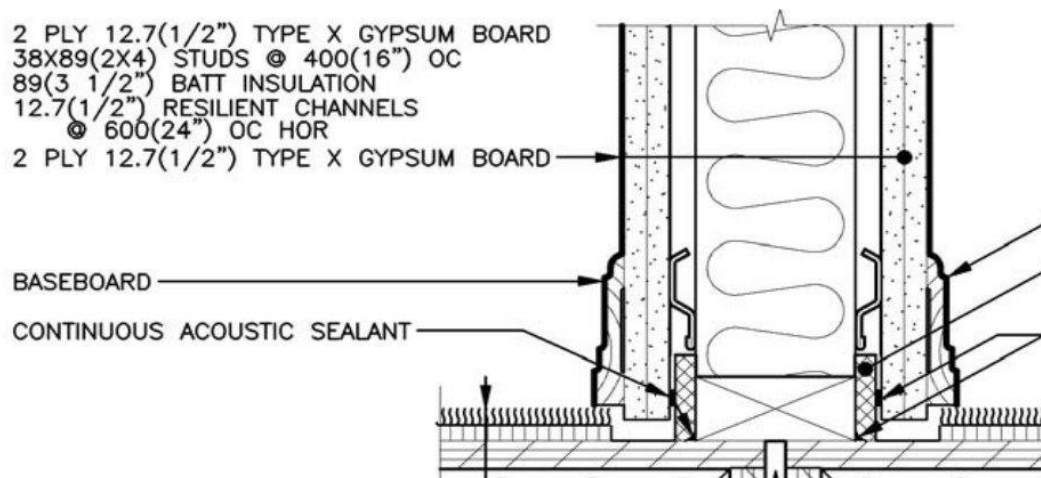



## ADDITIONAL RESOURCES

### OTHER RELATED GUIDES

- *Housing Construction in Nunavik*, Société D’Habitation Du Québec ([habitation.gouv.qc.ca](http://habitation.gouv.qc.ca))
- *Good Building Practices Guidelines*, Government of Nunavut ([www.gov.nu.ca](http://www.gov.nu.ca))
- *CMHC Best Practice Guide Fire and Sound Control in Wood-Frame Multi-Family Buildings*
- *City of Vancouver Noise Control Manual*

### BUILDING CODES AND STANDARDS

- *National Building Code of Canada*, National Research Council Canada ([www.nrc.canada.ca](http://www.nrc.canada.ca))



This technical booklet was developed to help community decision-makers and building officers choose different technical options in the delivery of residential housing for First Nations communities in remote northern Manitoba.

### **IMPORTANT NOTE**

This booklet addresses general acoustic approaches suitable for attached houses in northern communities. Specific detailing and careful construction on site are required in most cases and should be performed by an experienced contractor. The architect of record for the housing project should be the one to design and detail the acoustical and fire separation.

### **ACKNOWLEDGEMENTS**

This guide was funded and commissioned by FNNBOA and the National Research Council of Canada (NRC) and was prepared by Morrison Hershfield Limited. Additional funding was provided by Natural Resources Canada (NRCan), Canada Mortgage and Housing Corporation (CMHC), and Indigenous Services Canada.

Acknowledgement is extended to all those who participated as part of the project team, as external reviewers or as representatives of northern communities providing insight into what is needed to make this document useful.

### **ORIGINAL AUTHORS**

Morrison Hershfield Limited

### **REVIEWERS & CONTRIBUTORS \*Current (*Italicized original contributors*)**

*Alain Fournier, Founding Partner—EVOQ Architecture (Montreal, QC)*

\*Bruno Di Lenardo, Evaluation Officer—NRC Construction Research Centre (Ottawa, ON)

\*Claude Lawrenson—St. Clair College Architectural Technology (Windsor, ON) Retired Professor

*David T Fortin, Principal Architect/Associate Professor and Director—Laurentian University (Sudbury, ON)*

\* John Kiedrowski, Project Manager—FNNBOA (Ottawa, ON)

*Keith Maracle, President—FNNBOA (Shannonville, ON)*

*Larry Jones, Senior Project Officer—NWT Housing Corp. (Yellowknife, NWT)*