

BOOKLET 4: ELECTRICAL

TECHNICAL GUIDE FOR NORTHERN HOUSING



TAILORED FOR REMOTE NORTHERN MANITOBA COMMUNITIES





DISCLAIMER

The information in this publication is based on the most current research available to FNNBOA and has been reviewed by housing industry experts. Readers are advised to evaluate the information, materials and techniques carefully and to consult appropriate professional resources to determine courses of action suitable for their situations. The figures and text are intended as general practice guides only. Project and site-specific factors of climate, cost, geotechnical conditions and architecture must be taken into consideration. Any photographs in this book are for illustration purposes only and may not necessarily represent currently accepted standards. Electronic reproduction of content or this publication is made available for information only and is not an official version of the document. Individuals who download these documents do so at their own risk. FNNBOA will not be responsible for any damage to your computer or any of the information on it.

This document, or any discrete portion of this document (such as a chapter or section), may be reproduced for redistribution, without obtaining the permission of FNNBOA, provided that no changes whatsoever (including translation) are made to the text; that the entire document or discrete part is reproduced; that this copyright notice is included in its entirety in any and all copies of the document or any discrete part of the document; and that no use is made of any part of the document, or the name or logo of the owner of the copyright to endorse or promote any product or service. For any use of this document other than reproduction or for the general reference purposes as set out above, please contact First Nations National Building Officers Association at info@fnnboa.ca. For permission, please provide FNNBOA with the following information: Publication's name, year and date of issue.

First Nations National Building Officers Association

5731 Old Hwy #2, P.O. Box 219
Shannonville, Ontario K0K 3A0

www.fnnboa.ca

Tel (613)236-2040

info@fnnboa.ca

1st Edition [April 2024]

Provided by FNNBOA under licence from the National Research Council of
Canada



The story of house structures in the north

Electricity generation, distribution and demand are significantly more challenging in the remote northern context. Generation is mostly provided by diesel-burning stations, occasionally with limited supplementary power provided using hydro, solar and wind sources. Power outages and brownouts are more frequent in these communities due to these technical challenges.

Generated power is provided throughout the area using overhead lines, as buried lines would have to be buried very deep to reach below the frostline, making it extremely costly and in many cases unfeasible. With the population density being low, often with significant distance between homes, distribution is typically provided using a radial feed, with no redundancies. With long radial runs, service disruptions are frequent to residences. Installing a connection for a mobile generator is suggested for all homes for backup power to specific essential electrical loads when outages occur. This is a relatively inexpensive addition to the electrical system but can allow a region to timeshare a few mobile generators during a significant power outage and help ensure food remains frozen and homes stay above freezing temperatures.

Due to heating needs and larger occupancy levels in residences, electrical demand is high. Residences should focus on using energy-efficient equipment (e.g. washing machines, dryers and LED lamps for lighting fixtures) to reduce demand where possible. Additionally, equipment or appliances that create high peaks/ surges in demand, such as tankless electric instantaneous water heaters, should be avoided. Using an oil furnace as the primary source of heat and electrical baseboards as supplementary heat will also aid in minimizing residential demand (this method can eliminate 50 to 100 amps (A) of regular power usage from the electrical demand). A typical residence has a panel and service rated between 100-200 amps. A 20-amp electric hot-water tank replaced by a 113-amp instantaneous water heater will either cause frequent nuisance tripping of the panel main breaker when multiple loads are running or require an increase to the size of the main panel and service coming into the residence. A service size increase will lead to dramatic installation costs, increases for new occupancies and greater costs with the associated distribution system if it becomes common practice. For reference, the next common electrical panel size increase from 200A is 400A.

Centralized solar-farm systems can help reduce reliance on oil-burning generation and overall power-generation costs. They can also supply an alternate source of power to residences during outages or failures of diesel-generation stations.

It is critical to properly ground all connections at the transformer and service entrance and all electrical equipment throughout the residence. Undiscovered electrical faults will cause conductors to fail and possibly start a fire in the residence. With limited fire-fighting capacity in the northern environment, entire houses can be lost in the event of an electrical fire. Additionally, due to low soil conductivity, grounding grids are less effective in northern climates. This means more effort is required to provide proper grounding for each residence, ensuring that any fault picked up within the house can be dispersed safely until the fault is cleared (typically via a breaker tripping).



The story of house structures in the north

MORAL OF THE STORY:

Houses should have a plug-in for mobile generators to minimize disruption from power outages.

- When electricity is created by burning diesel, it is more efficient to use diesel-burning heating appliances (e.g. hot-water tank, furnace) instead of electric, from both a diesel-consumption and overall electrical-grid capacity perspective.
- For appliances powered by electricity, such as laundry washers and dryers, energy-efficient appliances and lamps are critical for residences with already high electrical demands. Coordinating mechanical systems with the electrical design team before implementation can significantly reduce electrical costs associated with northern houses.
- Implementing solar farms to supplement diesel power generation can greatly reduce diesel fuel usage and thus energy costs for residences and can provide limited power during distribution outages.
- Minimizing energy consumption is paramount where energy costs are extremely high. Where practical and economically feasible, all options should be explored to design and install systems that reduce energy consumption.



RECOMMENDED APPROACHES: *Electrical systems presented in this booklet*



Generation: Solar farms and diesel generation stations



Transformer and Distribution: Overhead power poles

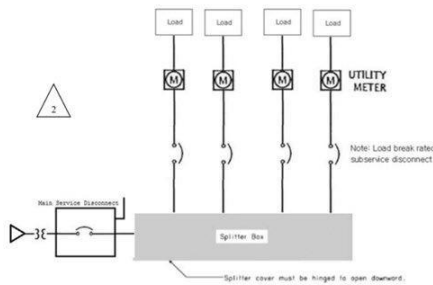

Service Entrance Connections: Splitters to individual panels

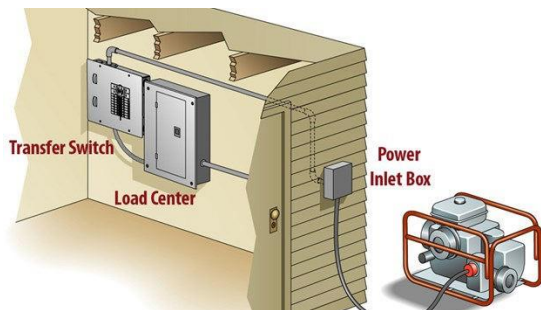

Backup Generator Transfer Switch: Sizing equipment needed



RECOMMENDED APPROACHES: *Electrical systems presented in this booklet*

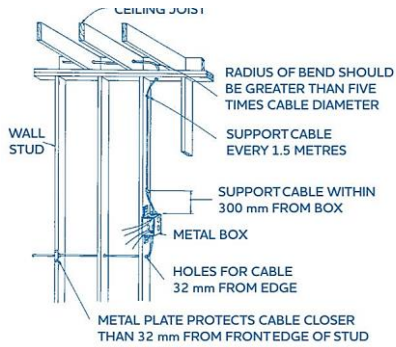

Wiring: NMD90 copper cabling



Lighting: Built-in LED arrays



Receptacles: Layouts and safety measures

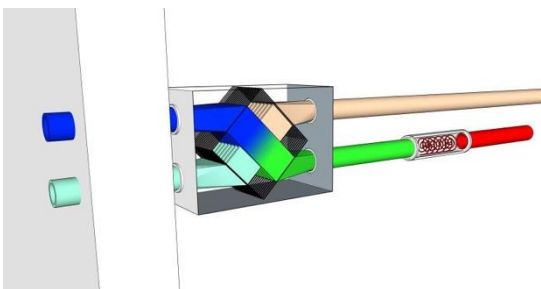

Ventilation: Supporting mechanical equipment (engineered wood)



RECOMMENDED APPROACHES: *Electrical systems presented in this booklet*



Heating: Supporting mechanical equipment

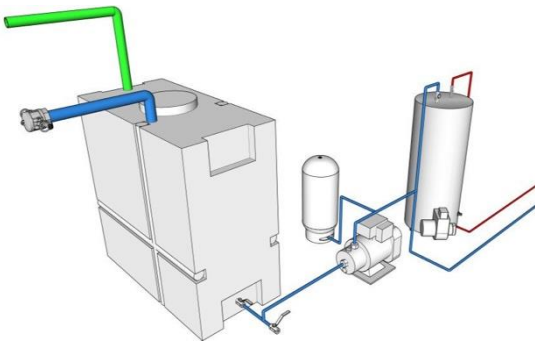

Plumbing Equipment: Water pump and pressure tank, hot-water heating, heat tracing for plumbing



Appliances: Importance of energy-efficient appliances



READ THIS BOOKLET IF YOU NEED TO:

Learn more about the electricity factors that should be considered when planning the construction of a new, **reliable**, and **efficient** house in a northern community.

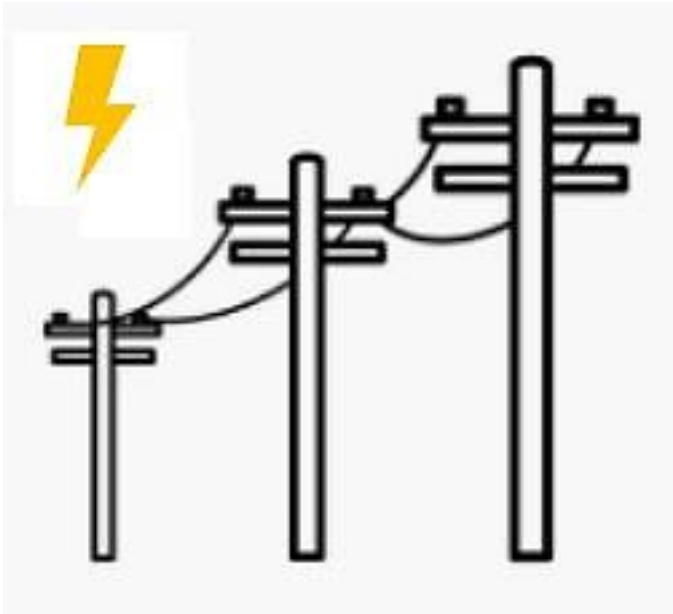

Reliable and efficient —The goal of this guide is to improve the overall well-being and quality of life for community members by advising on electrical approaches well suited to houses in the north, and construction challenges and constraints to consider so that electrical issues are avoided.



MAIN COMPONENTS

This booklet outlines the recommended general approach for designing electrical systems in northern Manitoba. Safety issues and overall challenges are summarized in the introductory booklet.

The electrical systems of a residential building can be divided into the following 11 main components:

1. Generation
2. Transformer and Distribution
3. Service Entrance Connections
4. Backup Generator Transfer Switch
5. Wiring
6. Lighting
7. Receptacles

Supporting components:

8. Ventilation
9. Heating
10. Plumbing Equipment
11. Appliances



GENERATION

Solar farms and diesel-generating stations





GENERATION

The traditional approach to power generation in remote communities is diesel generators. Single or multiple paralleled generators serve the power demands of the electrical distribution system. The typical capital cost for a 1.0 MW generator supply and installation is roughly \$1 to \$2 million. This is considering a 10-15-year service life before major replacement.

An example is illustrated below to provide an order of magnitude of typical installations.

Method/Assumptions

Sizing generation capacity:

- Assume 500 people in 100 houses.
- Assume other buildings include school, community centre, grocery store, restaurants and service buildings.
- Assume 70 kW peak per building x 10 buildings = 700 kW, but applying coincident factor (50 per cent), and demand factors per building (70 per cent), average demand is 250 kW
- Peak 26 kW per house x 100 houses = peak 2.6 MW, but applying coincident factor (30 per cent), and demand factors per house (60 per cent), average demand is 500 kW.
- Total demand = 250 + 500 = 0.75 MW, then installed generator rated at 1.0 MW (or 2 x 500 kW generators).

Consumption:

- Assume 50 per cent loading, on average, for generating plant: 18 gal/hr for 500 kW generator at 50 per cent loading.
- 8760 hours per year x 18 gal/hr = 160,000 gal/yr or 600,000 L/yr
- 600,000L/yr x 2-500 kW generators = 1.2 million litres of diesel/yr.



GENERATION

Many remote communities have opportunities to benefit from renewable energy, such as solar power. Solar panels can also be installed locally on houses or buildings to transform energy from the sun to electrical energy through inverters. Batteries may also be employed for energy storage produced from solar panels. Local solar-panel installations on buildings and houses can make sense economically in locations with established electrical power grids, such as towns and cities.

However, in remote communities, where small-scale power grids are not as robust and do not have the benefit of many steady power generation sources, it may not be the best option. Furthermore, local solar-panel installations on houses typically require additional electrical equipment for proper operation. The effective placement and installation of solar panels will vary from house to house, and more upfront design and planning is involved.

In contrast, solar, or photovoltaic (PV), farms typically consist of many solar panels grouped together in a central area. Electrical energy can then act as a central power generation source to supplement the energy provided by the diesel generator power plants. This would theoretically lessen the power output of the diesel generators and can also provide a baseline source of power if diesel generators are out of service for some reason. The feasibility and economics of such installations can vary from case to case, but when properly reviewed and designed, solar farms can be an effective means of offsetting diesel generators for power generation. Maintenance aspects of solar farms include cleaning snow and dust from the panels to ensure maximum output. Also, periodic testing and maintenance of the electrical equipment would be required to ensure the longevity of the system.



GENERATION

To continue with the example presented, a solar farm produces an average power output of 250 kW during the day. This can represent up to a 50 per cent average reduction in power output from the diesel generator plant. Depending on several performance factors for a best-case scenario, savings could reach an estimated 600,000 L of diesel per year.



Solar farm installation



Diesel-generating station—exterior



Diesel-generating station—interior



Transformer and Distribution

Overhead power poles





TRANSFORMER AND DISTRIBUTION

Power transformers and power lines are used to deliver power from power generation plants to end users in buildings and houses.

Overhead power poles and lines are preferred in remote communities for several reasons. They can be easier to troubleshoot, repair, and maintain because they are above ground. Also, due to ground frost levels and permafrost in some regions, it may not be feasible to bury transmission lines.

Power lines are installed on poles from generation plants to the communities. These typically consist of multiple conductor cables that are then connected to each service. One issue with power distribution lines is the effect of power-line losses. When electric current is transmitted through cables or conductors, they experience power loss, which is a function of the current through the conductors, and the resistance of the conductor (i.e. type of cable, length of cable). One way to decrease power losses is to increase the voltage of the conductors, which reduces the magnitude of the transmission current. Another option is to use specific conductors rated for higher voltages. Increasing the voltage of the cables is performed by “step up” power transformers that convert the voltage output of the diesel generators (which may be 600 V) to a higher voltage, for transmission of power over longer distances. Typical voltage at the distribution level (within communities) is between 7-13 kV. In large-scale distribution grids, voltage levels to distribute power over longer distances (10s or 100s of km) can be higher than these voltage levels.



Power-pole installations within a community



TRANSFORMERS AND DISTRIBUTION

“**Radial feeds**” are typically used in remote communities as they do not require any redundant or additional conductor/cable runs or poles and are therefore cost-effective. A radial system has only one power source for a group of houses. If a power failure occurs, it can interrupt power in the entire system, which would need to be fixed for power to be restored to all houses.

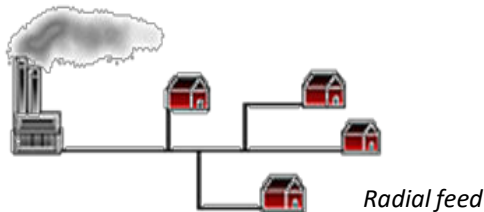

“**Loop feeds**” usually involve multiple power sources and power-conductor paths, which can provide better continuity of services, as end users can be connected to the system from multiple sources and routes. However, these loop systems require additional poles, conductors and equipment, such as switches to de-energize or re-route power from different sources. In general, these systems are more complex to implement and should be reviewed on a case-by-case basis to consider their feasibility.

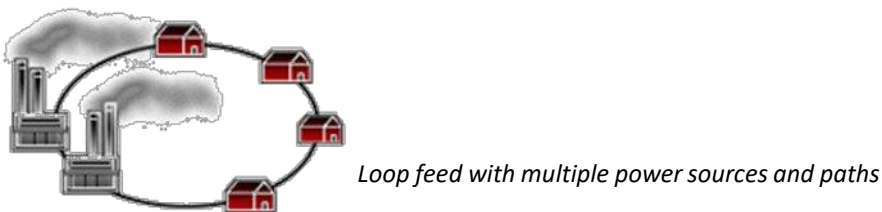

As radial feeds are more common in remote communities, reductions in overall load are more important to reduce failures caused by overloading the system. These failures can lead to blackouts and power interruptions, with many negative consequences for the community.



TRANSFORMERS AND DISTRIBUTION

Generation plants for communities may be in strategic areas some distance away from residential areas. As power distribution lines enter local areas, voltage must be stepped down to utilization levels, usually 120/240V single phase for houses, and in some larger-scale buildings, three-phase 600/347V or 208/120V. Feeds to each house or building are typically via pole-mounted transformers. Conductors are then routed to each building and service entrance/main disconnect or panel.



Power-pole distribution in a community



Power-pole installations in a community



Diesel-generating station with step-up transformers to power poles



SERVICE-ENTRANCE CONNECTIONS

Splitters to individual panels





SERVICE ENTRANCE CONNECTIONS

Service entrances to houses are typically provided using neutral-supported cable from the pole-mounted transformer into a service mast and connected to the main disconnect or main panel. In the case of a duplex or multiplex, service conductors can be consolidated into one main disconnect, and then further distributed to the individual panels through a splitter and multiple disconnects. Having separate disconnects for each panel can allow shutdowns for servicing an individual panel or unit without interrupting other units.

Service grounding must be installed at two critical locations for each feed for a house or building: one at each pole-mounted transformer that feeds a building or house, and one at the main service disconnect of the building or house. Typically, this consists of grounding electrodes driven into the earth. In some regions, deep frost levels and permafrost make it difficult to install grounding electrodes. In these cases, other strategies should be explored to ensure proper grounds are provided. Some techniques might include installing ground rods as deep as possible and backfilling with treated soil to increase the conductivity of the ground system. Careful consideration must be given at the design stage to select the best possible grounding system for each specific location. Grounding is important for many reasons, but primarily because it provides electricity a low impedance path to the earth. Establishing a good ground in the electrical system can prevent injuries and fires resulting from inadvertent electric shock.



Splitter-feeding multiple disconnects for individual houses



SERVICE ENTRANCE CONNECTIONS

It is recommended that the service disconnects, and panels be in a mechanical/service room with clear access in front of the panel of at least one metre. This is to ensure that proper access to the panel is provided should any repairs or servicing be required.

Based on the expected loads of a typical remote-community home, it is recommended that a 120/240 V, single phase, three-wire, 150 A, minimum 40-circuit panel be installed for each home. The main feeders to the panel should be sized to 150 A, and loading on the panel should not exceed 80 per cent of this rating for any prolonged period. Unless specifically noted otherwise, when conductors or bushing are subject to more than 80 per cent of their rating for long periods, overheating can occur, causing damage to conductor insulation or nuisance tripping of overcurrent protection.

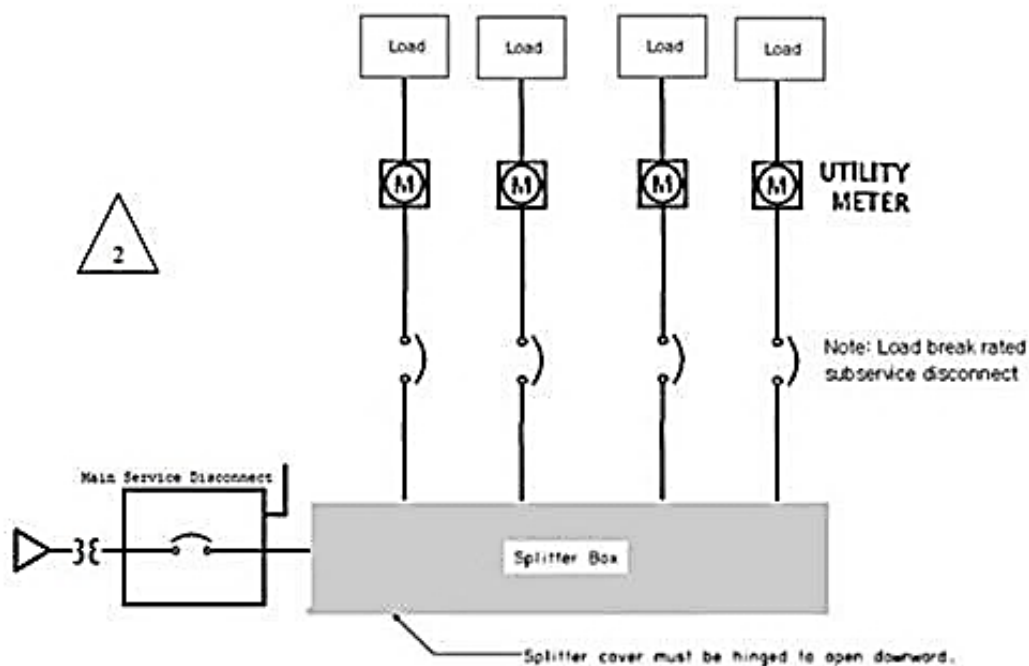

Splitter-feeding multiple disconnects for individual houses



SERVICE ENTRANCE CONNECTIONS

A manual transfer switch and sub-panel to feed essential circuits are also recommended and described in the next section. These ratings are based on the following assumptions: Detailed review and confirmation of the specific loads should be performed for each case to ensure proper sizing of panels in each house.

The main breaker and branch circuit breakers on the panel should be bolt-on, molded-case circuit breakers. Circuit breakers are recommended as they can be reset and do not need to be replaced upon tripping. This allows for multiple operations and avoids the need to have replacement fuses ordered and installed in the panels.

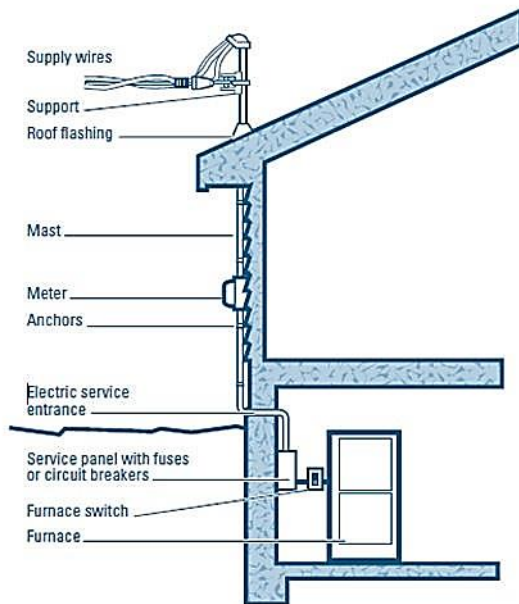

Typical service entrance installation

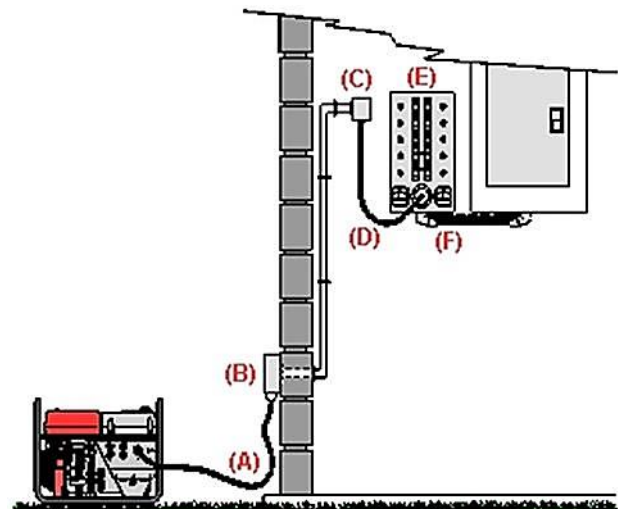

Typical service entrance installation



SERVICE ENTRANCE CONNECTIONS

It is recommended that circuit breakers protecting the various circuits within the home are combination arc-fault circuit-interrupter (AFCI) type. Exceptions include the following: kitchen counter, island and peninsula outlets, kitchen refrigerator outlet, and cord-connected sump pump on a separate breaker. Arc-faults are unintended arcs created by current flowing through an unplanned path. An example would be where an arc is created through the exposed conductors of a bent or damaged cord. Electricity then flows through the unintended path of the cord insulation or surrounding materials rather than the conductors within the cord.

Arcing can potentially ignite surrounding materials, or insulation within walls and ceilings, resulting in a fire. AFCIs act to detect the arcs, shut down and trip the circuit to prevent the arc from continuing.

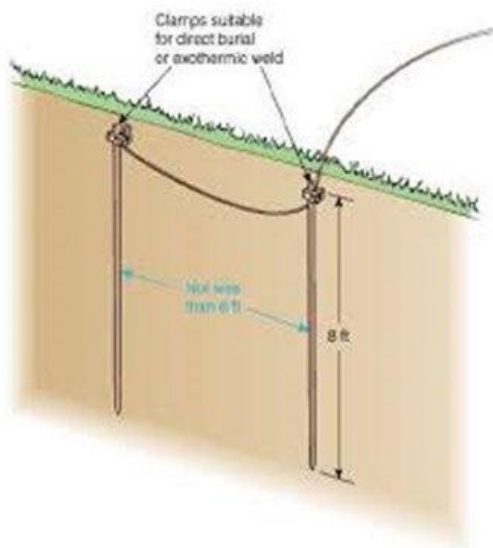

Typical grounds of service entrance installation



Typical ground installation



BACKUP GENERATOR TRANSFER SWITCH (Sizing what equipment is needed)

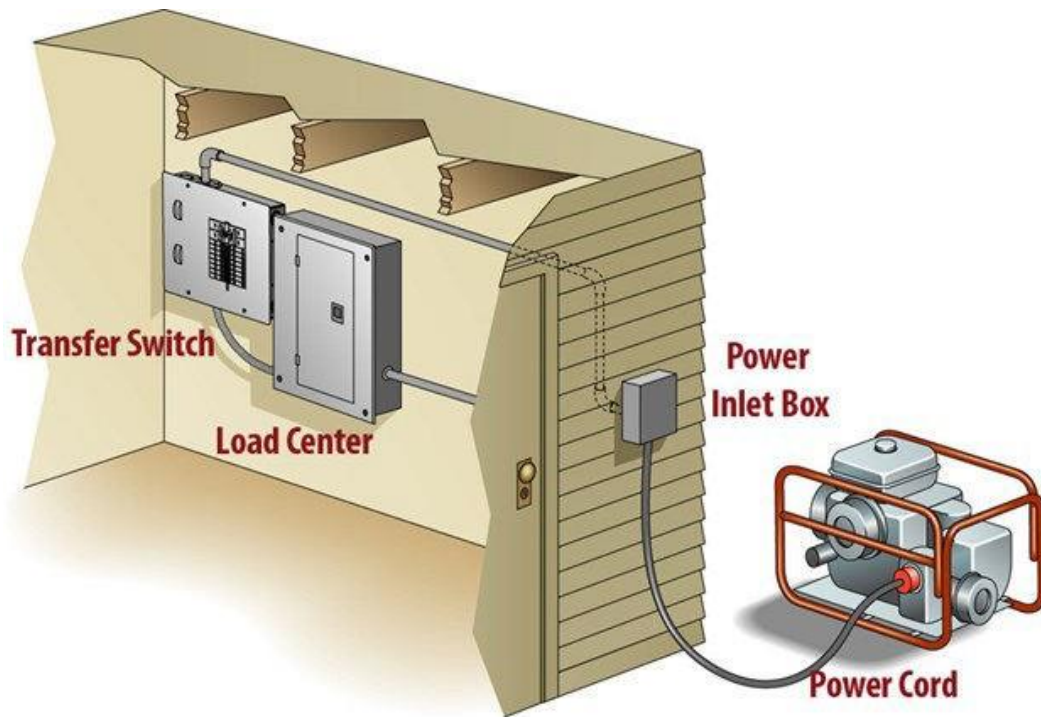



SERVICE ENTRANCE CONNECTIONS

Power outages and disruptions are common in many remote communities, which poses challenges for occupants. It is therefore recommended that each home have a manual transfer switch and sub panel to feed essential loads, such as refrigerators, freezers, lighting, heat trace and possibly the backup baseboard heating, via a portable generator connected through a power-inlet box on the exterior of the building. The sub panel would normally be fed from the main panel, and in the event of a power outage, the sub panel would also be wired to be fed from the standby portable generator through the power-inlet box.

Portable generators can then be shared and circulated throughout the community during prolonged power outages, to ensure households can avoid food spoilage and keep indoor temperatures above freezing.



Backup generator

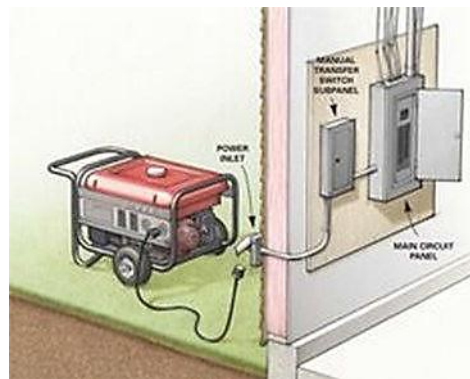

Generator connected to emergency + main power panel



SERVICE ENTRANCE CONNECTIONS

Portable generators can also serve a secondary purpose during any construction season in the community. They can range in size from 1 kW to 15 kW. As an example, a 12-kW portable generator would be coupled with a 60 A connection point at the power-inlet box, which then connects to a 60 A, 120/240 V sub panel. Either the manual transfer switch or circuit breaker for the portable generator should be mechanically interlocked with the main breaker on the house panel, to prevent back feeding to the grid when the grid is down.

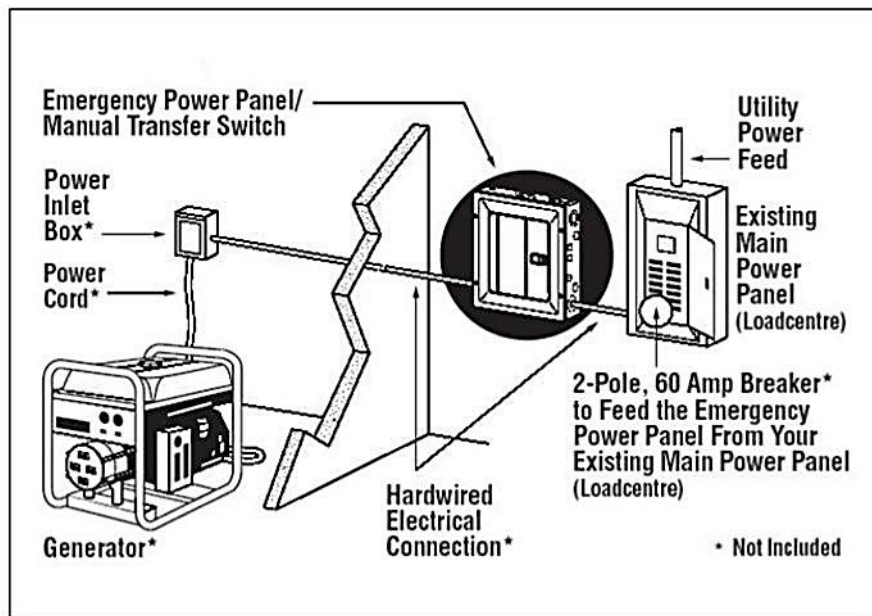

Generator, emergency + main power panel



WIRING

NMD90 copper cabling

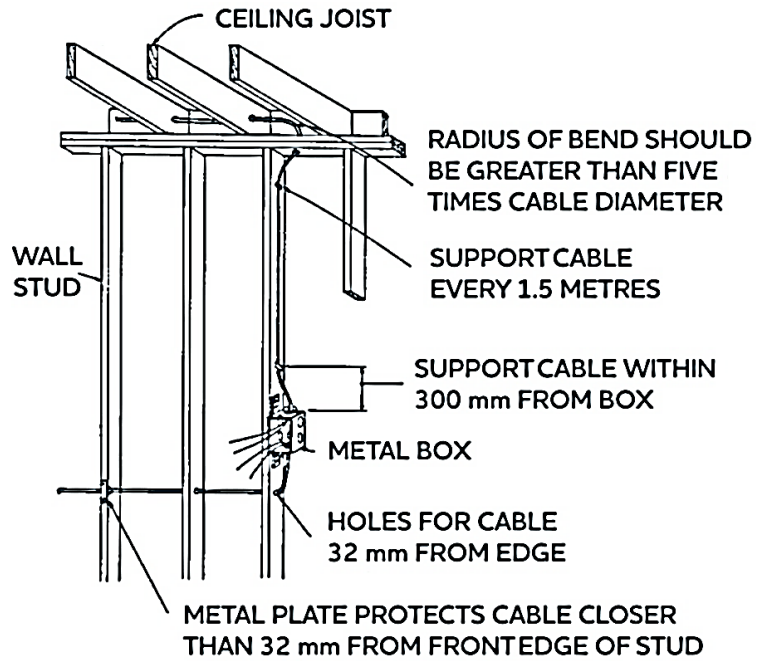



WIRING

Branch circuit wiring within the home is typically NMD90 copper cabling, which consists of two copper conductors and one ground wire within a non-metallic jacket used for dry locations. These cables can be installed within stud walls and ceiling spaces throughout the home. Where wiring is exposed and subject to mechanical damage, such as in service rooms, AC90 cable (also commonly known as BX cable), which consists of two copper conductors and a ground wire within an interlocking aluminum armour, can be used. Copper conductors are recommended over aluminum wiring, as aluminum wiring connections/terminations tend to loosen over time, and these loose connections can result in unwanted arcing and fires.

Sizing of cables will vary based on the types of loads being fed. For general 15 A or 20 A receptacles throughout the house, #14 AWG wire is usually used (as it is rated for 20 A at 75 degrees C terminations). For larger load applications, wire is typically upsized to meet the ampacity requirements of the equipment. For example, a stove requiring 40 A will be fed using #8 AWG wire, which is rated for 50 A.

Junction boxes or outlet boxes are used either for any intermediate wiring connection points, or for installing switches, lighting fixtures, or receptacles for end-use equipment. Junction boxes should be properly secured to studs or ceiling members, and sized accordingly to not overcrowd the box, which can lead to overheating and is a fire hazard.

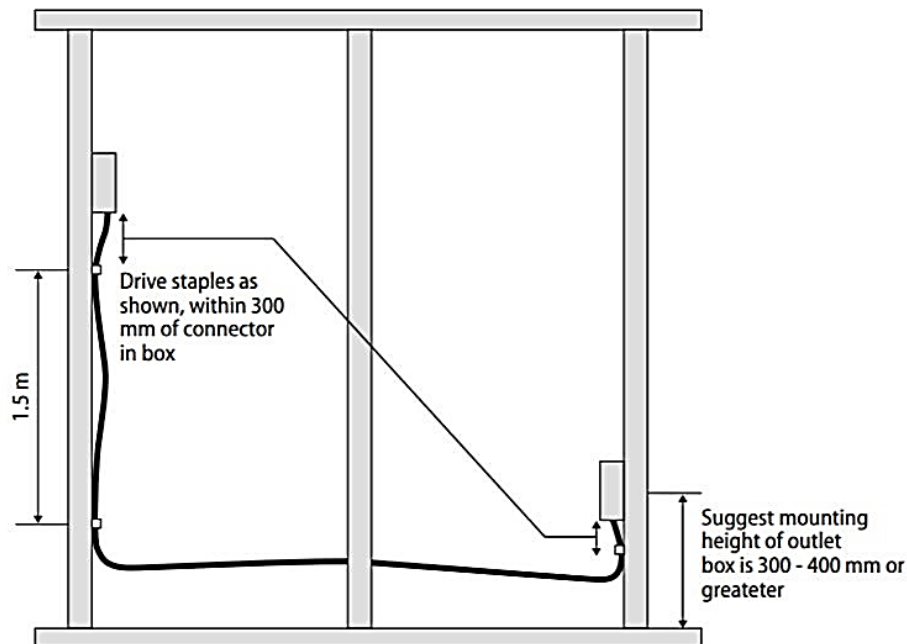



LIGHTING

Built-in LED arrays





LIGHTING

Good lighting makes a home comfortable and functional. It should be effective and efficient. Proper light levels should be provided according to the specific use of each space. For example, in the kitchen, where food is prepared, a higher level and coverage of light should be provided. Exterior lighting should be located at entrance steps, walkways, stairs, and exit doors, for safety and security.

When selecting the exact type of fixtures and bulbs required, focus on how effectively they project light, ease of maintenance and replacement, and optimal energy efficiency. It is recommended that home fixtures allow for the installation of bulbs, rather than, for example, integrated LED fixtures (complete fixtures with LED arrays built in). This allows occupants to easily replace lightbulbs when they fail, and no special installation or re-installation of fixtures is required when the fixture reaches its end of life.



LED lightbulb



Flat LED light



LIGHTING

Common lightbulb types in today’s market for residential applications include incandescent, fluorescent, compact fluorescent (CFL), and most recently, light-emitting diode (LED) types. A comparison of the different power and light output ratings is provided below. It is recommended that LED lamps and bulbs be used in light fixtures for their low energy usage, efficient light-output properties, and long lifespan, compared to CFL and incandescent light sources. Energy Star-rated lamps and bulbs should be used for lower energy usage throughout. Lamp types should be minimized and standardized throughout the community as much as possible to simplify the process of providing replacement bulbs as they reach the end of their service lives.

Lighting should be controlled by manual on/off switches strategically placed in each area or room. In some cases, such as a stairwell, a three-way switch should be installed at the top and bottom landings to allow for control of the lighting fixtures from either floor level. In addition, switches should have integrated dimmers, which allows for flexibility and adjustment of light levels for occupant comfort and specific tasks being performed.





RECEPTACLES

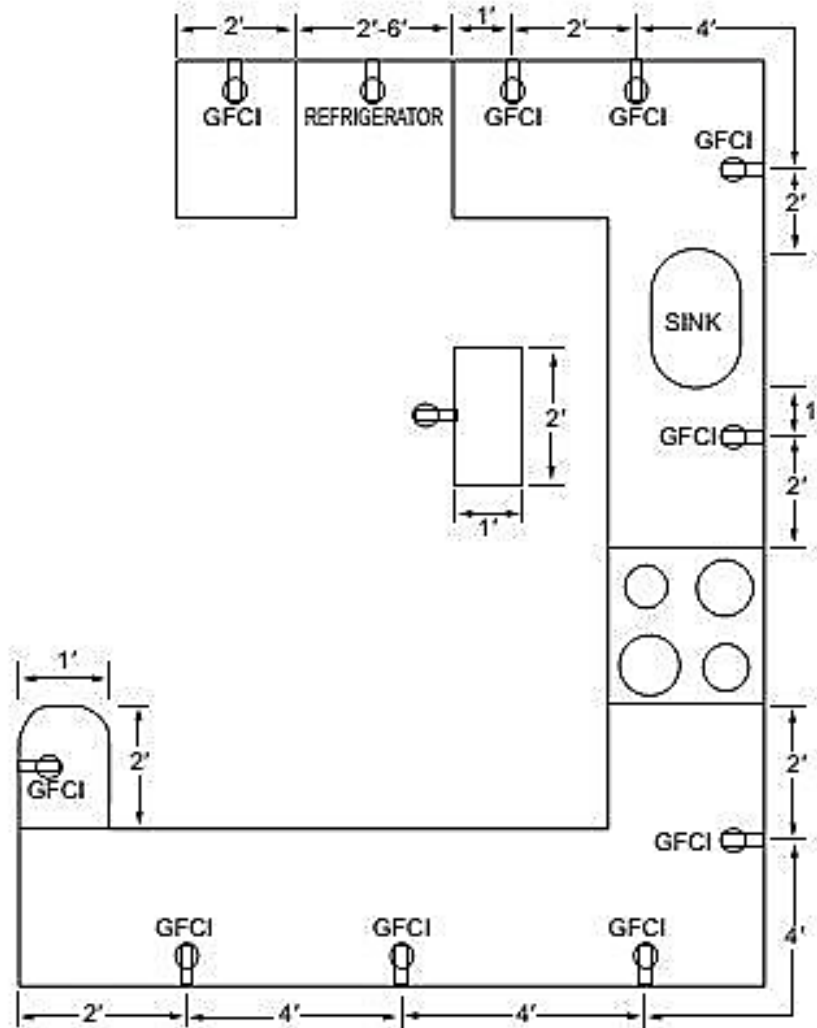



RECEPTACLES

Receptacles and outlets allow for plugging in appliances or equipment within the home, and are typically rated 120 V, 15 A or 20 A, except for special dedicated loads that draw more power, such as an electric range, which would be rated 240 V, 40 A or more, depending on the specific rating of the equipment.

In general, receptacles within the home should be “tamper resistant.” Tamper-resistant receptacles prevent insertion of objects, which can cause shocks, burns, fires or damage to equipment.



Standard receptacle with open slots



Tamper-proof receptacle with internal mechanism to prevent insertion of objects other than plugs



RECEPTACLES

Where receptacles are near bathtubs, showers or sinks, it is necessary that ground fault circuit interrupter (GFCI) receptacles be installed. Like AFCI devices, the GFCI acts to trip circuits when it detects an unplanned path of electricity.

In general, spacing between general-purpose receptacles throughout the house should be a maximum of 3.6m along any continuous wall section, or 1.8 m from a receptacle to a wall opening or obstruction (e.g. door, fireplace). This ensures that appliances or electronics can easily be plugged in without the use of long extension cords, which can become a hazard for tripping or a source of arcing in the case of an old or damaged cord. It also reduces the need for power bars where multiple plugs are used in a specific area.



GFCI receptacle



AFCI "breaker" used in a breaker





RECEPTACLES

For counter work surfaces, receptacles should be spaced within shorter distances (1800 mm spacing between continuous wall sections, and 900 mm for a receptacle to a wall obstruction), to allow smaller kitchen appliances to be plugged into a kitchen counter or island, or tools for a workbench application.

Recommendations for layouts and spacing for receptacles are shown below. In addition, as in the schematic on the first page of this section on receptacles, outlets near water should be GCFI receptacles.

Receptacles in a kitchen

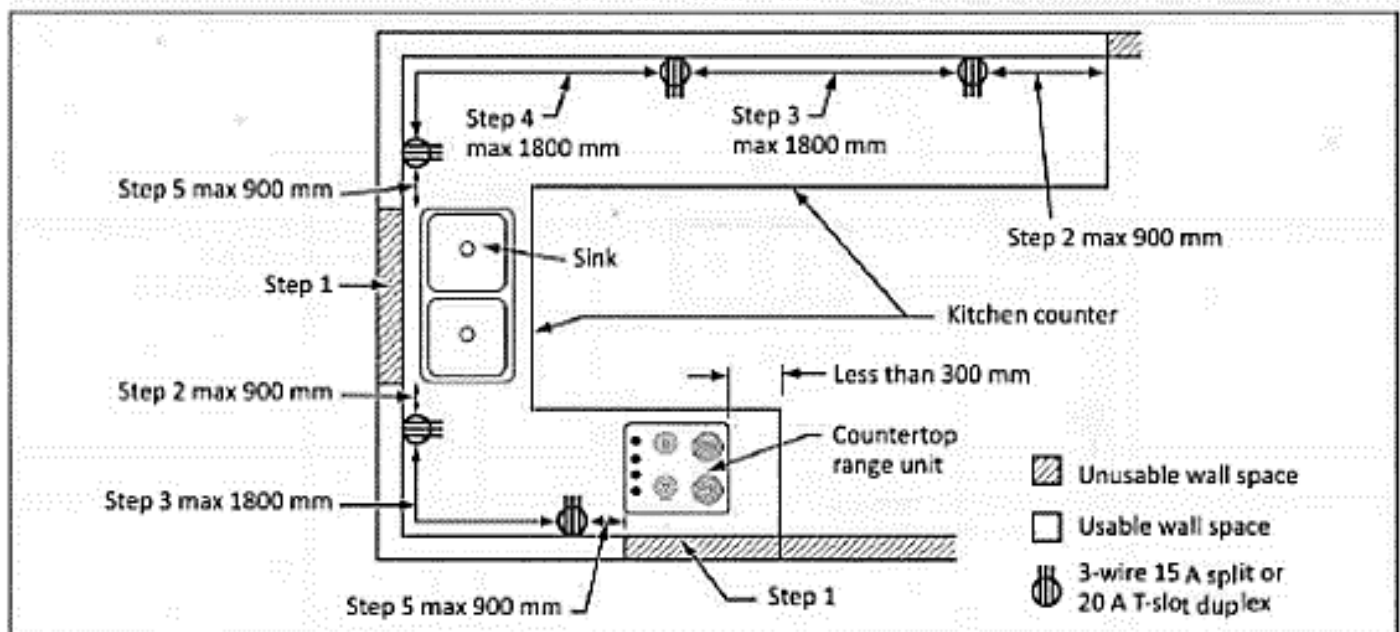



WIRING

It is also necessary that a maximum of 12 outlets (or six duplex receptacles) be grouped on a single 15A circuit. This is to prevent circuits from being overloaded, which can lead to conductor or insulation damage, as well as nuisance tripping of breakers.

Receptacles for dedicated equipment such as major appliances should be on separate, dedicated circuits. These receptacles should be installed at their intended location to avoid any extension cords being used and to prevent any other equipment from being plugged into those specific points.

Recommendations for layouts and spacing for receptacles are shown below.

Receptacle layout — Living and dining room

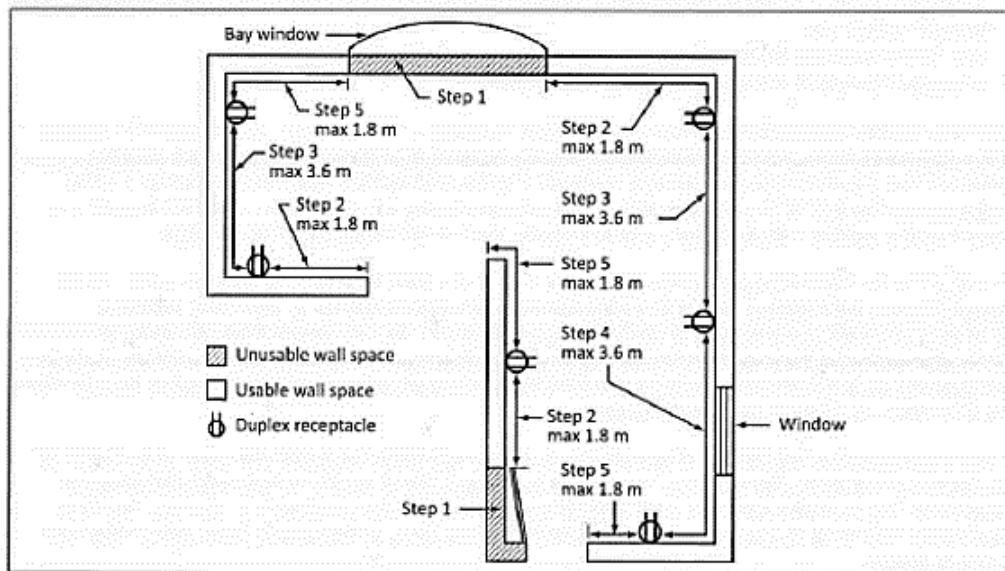

Receptacle layout — Bedroom

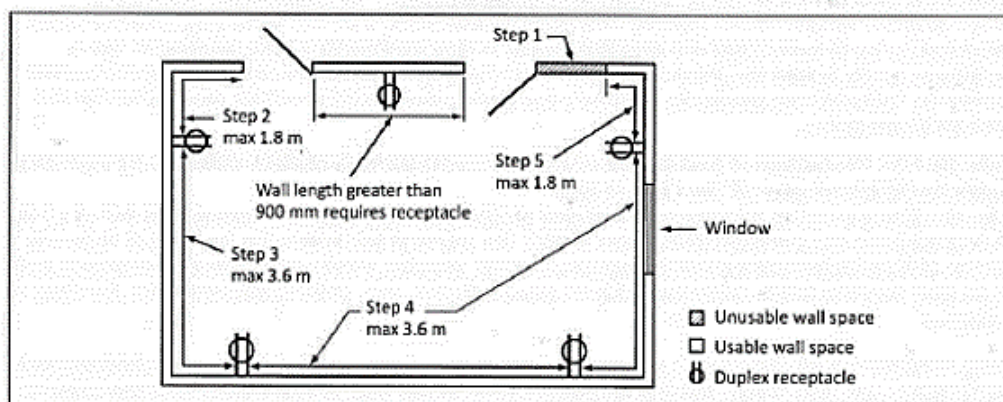



VENTILATION

Supporting mechanical equipment

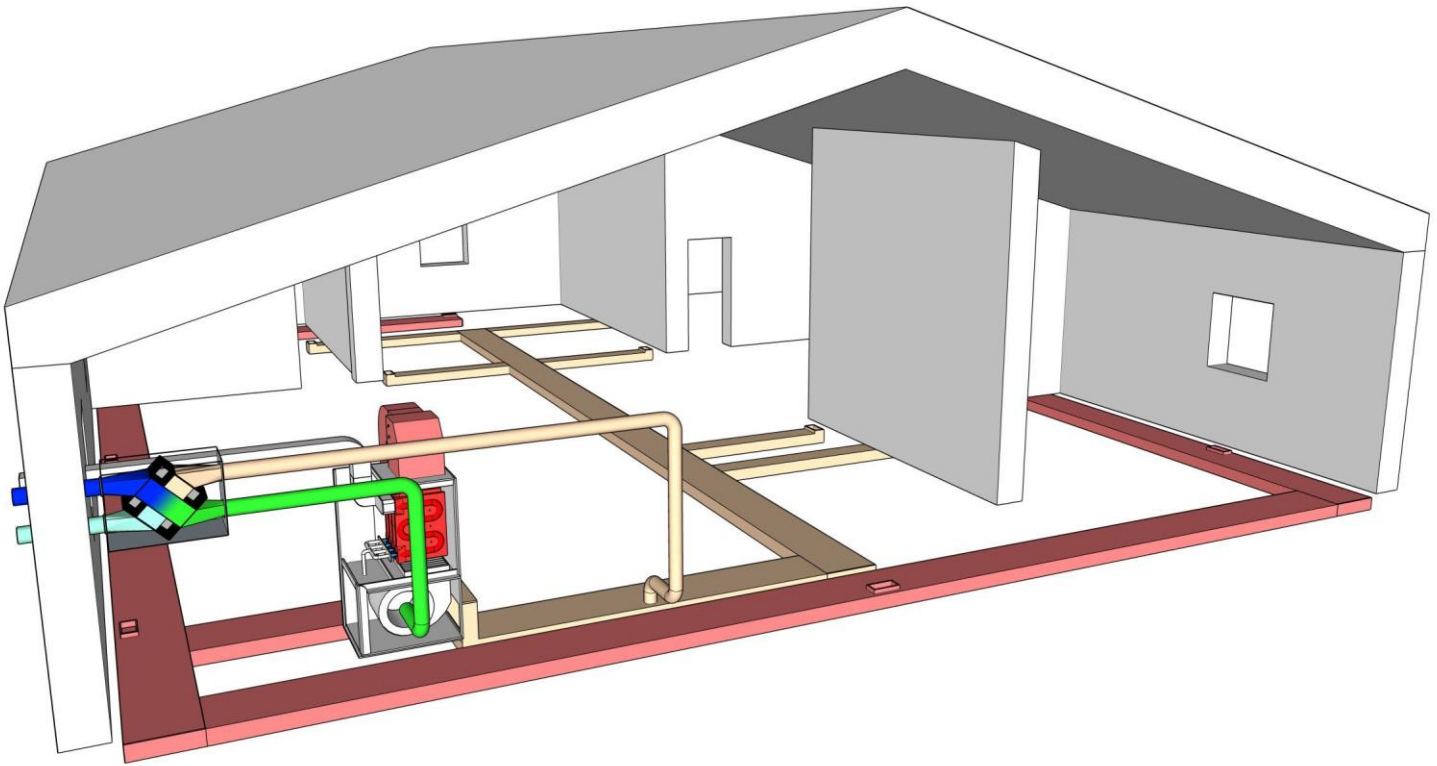

Air-distribution ducts in a house connected to a furnace and HRV that require electricity to run fans and the on/off controls



VENTILATION

Ventilation equipment within the home typically consists of exhaust fans and, in some cases, heat-recovery ventilators (HRVs) or energy-recovery ventilators (ERVs). Specification of this equipment should be coordinated with the mechanical design to ensure proper supply voltages to the equipment are provided. Furthermore, it is recommended that the equipment be energy-efficient, either by confirming that the motors are high efficiency, and/or ensuring the equipment bears the Energy Star symbol, which represents the most efficient models compared to other models in the same class.

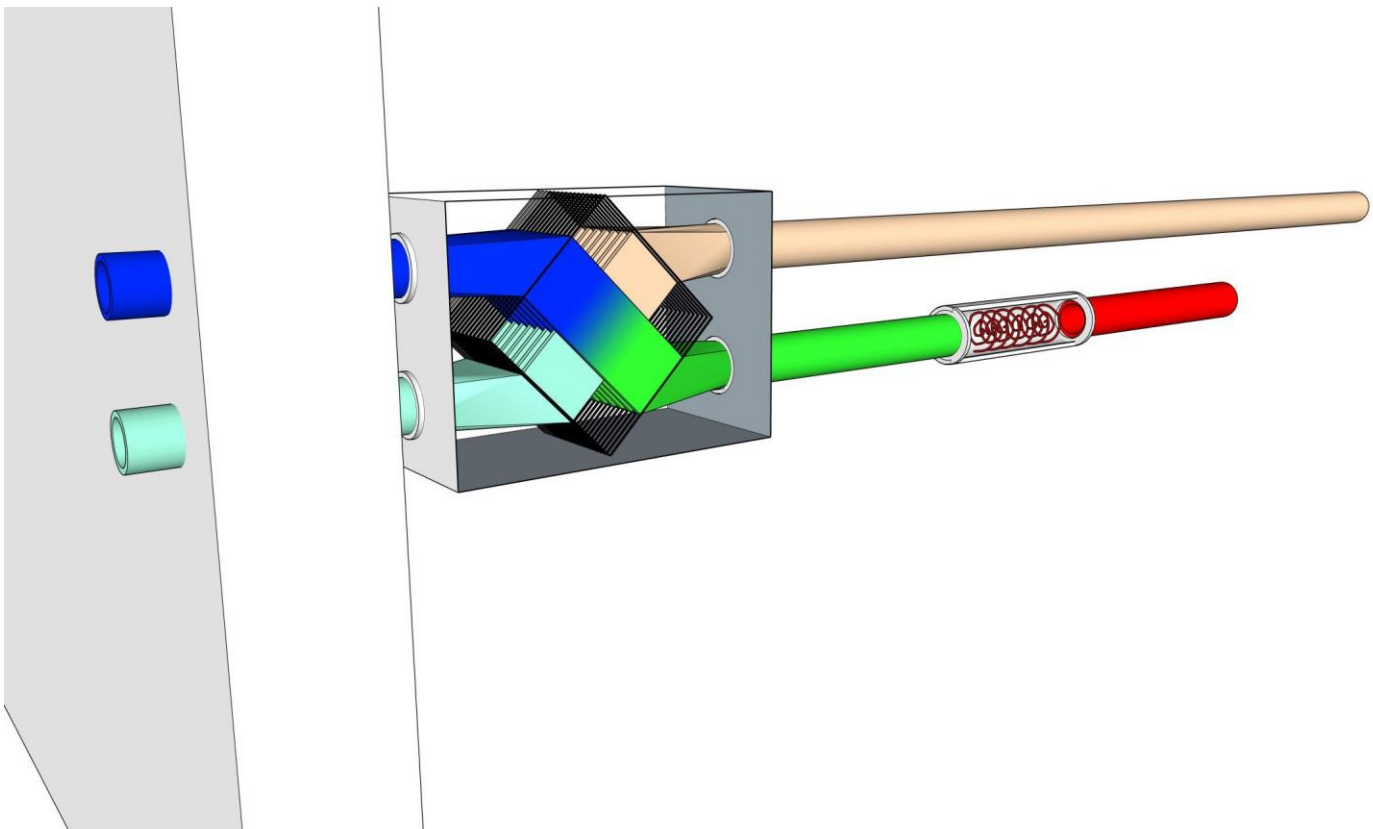

HRV and an inline duct heater that require electricity to function



HEATING

Supporting mechanical equipment

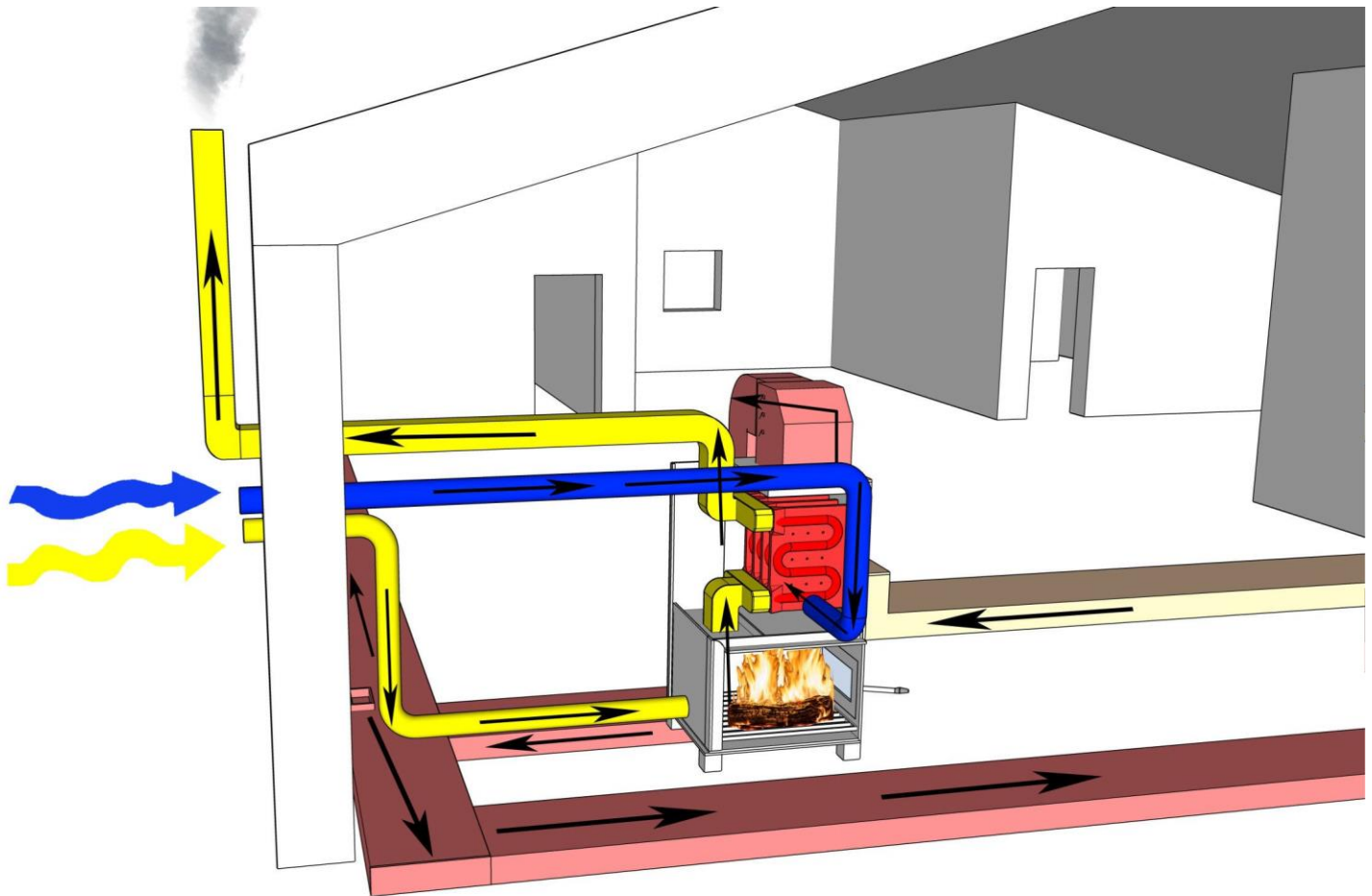

A wood-burning furnace connected to air distribution ducting. The fan for the air-distribution ducting requires electricity to function.



HEATING

Space heating is typically one of the largest energy draws in the house. It is therefore recommended that electric baseboard heaters be used only as secondary or backup heating. For example, in a 2,500 ft² home, a total of 5 kW of baseboard heat equipment may be installed for backup heating purposes. At 240 V, this translates to roughly 21 amps, which is 20 per cent of a 150-amp panel's available peak ampacity. Where multiple houses within the community use electric baseboard heat simultaneously and for prolonged periods, this would not only mean high individual operating costs due to electric-load draw but also strain on the power generation system, with the collective added demand.

It is also recommended that baseboard heaters be installed with individual controls either built into the units, or controlled by a thermostat, to allow users to adjust settings, and to shut the equipment off when it is not required.

Baseboard heaters should be installed following manufacturer recommendations. Typically, supply voltages can be either 120 V or 240 V feeds. Circuit breakers and wiring should be sized according to the load.





PLUMBING EQUIPMENT

Water pump and pressure tank, hot-water heating, heat tracing for plumbing

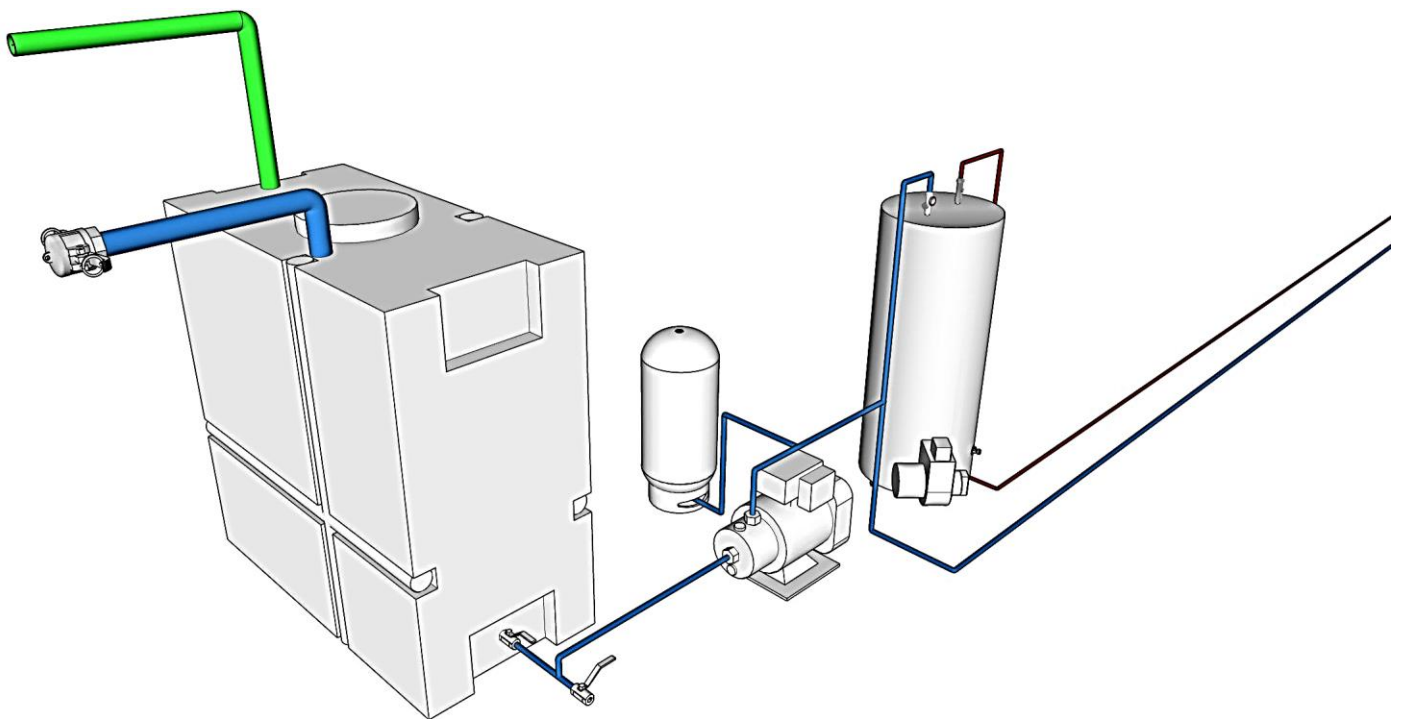



PLUMBING EQUIPMENT

Where possible, oil-fired hot-water tanks are recommended in houses versus electric water-heater tanks. Water-tank heating can amount to a significant load within the house. Minimizing the electrical load on the home and in the entire system is beneficial.

Typical electrical demands for an electric hot-water heater are around 4.5 kW for a 60-gallon tank.

In comparison, a tankless water heater to replace an oil heater or electric water tank can be rated at approximately 24 kW, which can draw upwards of 100 A. There are several reasons why a tankless water heater would not be ideal for a home application. It would require extra breaker spaces to accommodate the larger breaker sizes and quantities, and the increased demand load would require upsizing the electric panel ratings, as well as the feeder conductors supplying the panel. The increased load, if installed in multiple houses in the community, would put a strain on the electric distribution system components and generating facilities.

For these reasons, it is recommended that instantaneous hot-water equipment be considered only in buildings that are seldom used, or where hot-water demand from occupants is hourly or daily.



Hot-water tank



Instantaneous hot-water heater



APPLIANCES

The importance of energy-efficient appliances

Canada

ENERGUIDE

Energy consumption / Consommation énergétique

300 kWh

per year / par année

▼ This model / Ce modèle

285 kWh
484 kWh

<p>Uses least energy / Consomme le moins d'énergie</p> <p>Similar models compared</p> <p>Model number</p>	<p>Type 3</p> <p>16.5 – 18.4</p> <p><i>volume in ft.³ / volume en pi³</i></p> <p>00000</p>	<p>Uses most energy / Consomme le plus d'énergie</p> <p>Modèles similaires comparés</p> <p>Numéro du modèle</p>
--	---	--

Removal of this label before first retail purchase is an offence (S.C. 1992, c. 36).
Enlever cette étiquette avant le premier achat au détail constitue une infraction (L.C. 1992, ch. 36).

The **ENERGY STAR**[®] mark on this EnerGuide label signifies that this is an energy-efficient appliance. Its energy performance meets or exceeds the Government of Canada's high efficiency levels. Use the EnerGuide rating to determine how this appliance compares to other similar models.

La marque **ENERGY STAR**[®] sur cette étiquette ÉnerGuide signifie que l'appareil est éconergétique et que son rendement énergétique satisfait ou dépasse les niveaux de haute efficacité du gouvernement du Canada. Utilisez la cote ÉnerGuide afin de comparer le rendement de l'appareil avec celui d'autres modèles similaires.



PLUMBING EQUIPMENT

Major appliances are typically one of the largest energy draws within the home. It is therefore important that these appliances be energy efficient. Energy Star is a common symbol on many major appliances within Canada. It indicates that the appliance has been tested to higher efficiency standards than other models.

EnerGuide labels are also commonly seen on appliances and usually include a few major items, such as the annual energy consumption of the product in kilowatt-hours (kWh). Another is the energy consumption indicator, which shows the model's performance compared to the least and most efficient models in the same class.

Products with lower energy consumption, given the performance of the model desired, will draw less energy than other comparable models in the same class.

As mentioned in previous sections, major appliances with higher current draws will usually require special receptacle types and wiring to suit the application. For example, a dryer may require a 30-amp receptacle and #10 AWG wiring to account for the higher current draws.





ADDITIONAL RESOURCES

BUILDING CODES & STANDARDS

- **CSA C22.1:21 *Canadian Electrical Code, Part I, Safety Standard for Electrical Installations***, Canadian Standards Association
(<https://www.csagroup.org/store>)
- ***National Building Code of Canada***, National Research Council Canada (www.nrc.canada.ca)

OTHER RELATED GUIDES

- ***Good Building Practices Guidelines***, Government of Nunavut
(www.gov.nu.ca)



This technical booklet was developed to help community decision-makers and building officers choose among different technical options in the delivery of residential housing for First Nations communities in remote northern Manitoba.

IMPORTANT NOTE

This booklet addresses general electrical generation, distribution systems and the house electrical system suitable for houses in northern communities. All electrical system planning, and installation must be carried out by a certified electrician, preferably with experience in northern houses. The electric system and backup system within a First Nation house must meet the needs of the occupants, and occupants should be consulted for specific interior house situations and planned operations.

ACKNOWLEDGEMENTS

This guide was funded and commissioned by FNNBOA and the National Research Council of Canada (NRC) and was prepared by Morrison Hershfield Ltd. Additional funding was provided by Natural Resources Canada (NRCan), Canada Mortgage and Housing Corporation (CMHC), and Indigenous Services Canada.

Acknowledgment is extended to all those who participated in this project as part of the project team, as external reviewers or as representatives from northern communities providing insight into what is needed to make this document useful.

ORIGINAL AUTHORS

Morrison Hershfield Limited

REVIEWERS & CONTRIBUTORS - *Current (*Italicized original reviewers*)

Alain Fournier, Founding Partner—EVOQ Architecture (Montreal, QC)

*Bruno Di Lenardo, Evaluation Officer—NRC Construction Research Centre (Ottawa, ON) Retired

*Claude Lawrenson- St. Clair College Architectural Technology (Windsor, ON) Retired Prof.

David T Fortin, Principal Architect/Associate Professor and Director—Laurentian University (Sudbury, ON)

* John Kiedrowski, Project Manager—FNNBOA (Ottawa, ON)

Keith Maracle, President—FNNBOA (Shannonville, ON)

Larry Jones, Senior Project Officer—NWT Housing Corp. (Yellowknife, NWT)